

## Kirchoff's Circuit Laws

### Pre-lab questions

1. What is the goal of this experiment? What physics and general science concepts does this activity demonstrate to the student?
2. What is a statement (*in words*) of Kirchoff's junction rule?
3. Looking at Figure 2 in the lab below, express  $V_C$  as a fraction of  $V_0$ .

The goal of this experiment is to understand the voltages and currents occurring in a resistive DC circuit (that cannot be treated simply through the series or parallel circuit element concepts utilized to this point), and to see if Kirchoff's rules work for this type of situation.

### Introduction

Kirchoff's rules (sometimes referred to as laws) are a generalization of certain physics conservation laws already in use. Namely, they involve the conservation of electric charge and the conservation of energy. In the context of moving electric charges (current) and dynamic equilibrium (so the time constancy of energy implies zero net power around a complete circuit), Kirchoff's rules become:

1. Junction Rule: The net electric current flowing into any point is zero at all times, where we use the convention that current into a point is positive and current out of the point is negative.

$$\Sigma I = 0 \quad (1)$$

2. Loop Rule: The sum of the voltage drops around any closed loop must equal zero, where the drop is negative if the voltage decreases and positive if the voltage increases in the direction that one goes around the loop.

$$\Sigma V = 0 \quad (2)$$

### Equipment

Resistive/Capacitive/Inductive Network, AC/DC Electronics Laboratory, 3 PASCO voltage sensors, 2 PASCO current probes, set of short patch cords.

### Experiment

Kirchoff's Laws form the basis of all circuit analysis. Here we verify the laws for a resistive circuit using a DC input.

Lab experiment #9 [Based on PASCO Kirchoff's Circuit Laws lab, written by Chuck Hunt]

We will apply Kirchoff's rules to the "Y" circuit shown in Figure 1.  $V_o$  will be the supply voltage from Output 1 of the 850 Universal Interface.  $V_C$  will be produced by the voltage divider setup shown in Figure 2. We will not attempt to calculate  $V_C$ , but will measure it directly. To solve for the three unknown currents, we need three equations. Applying Equation 1 at point A in the circuit:

$$I_1 + I_2 - I_3 = 0 \quad (3)$$

where we take current flowing in as positive and current out as negative. Applying Equation 2 around loops 1 and 2 yields:

$$R_1 I_1 + R_3 I_3 - V_C = 0 \quad (4)$$

$$-R_2 I_2 - R_3 I_3 + V_o = 0 \quad (5)$$

where the voltage is negative if we go from high voltage to low (with the current arrow across a resistor).

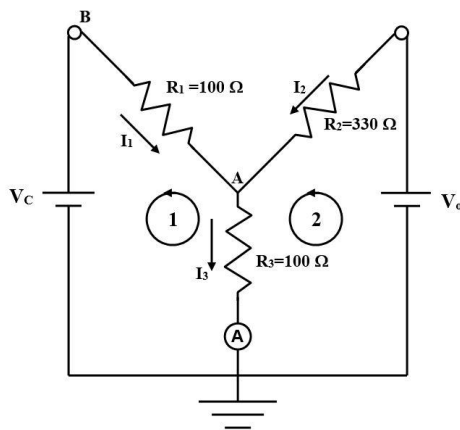

Figure 1: "Y" Circuit

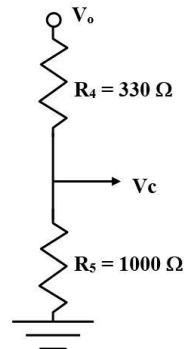

Figure 2: Voltage Divider

## Resistor Calibration

1. In PASCO Capstone, open the Hardware Setup and click on Signal Generator #1 on the 850 Universal Interface and select the Output Voltage Current sensor.
2. Plug in a Voltage sensor to Channel A on the interface.
3. Open the Data Summary and click on the Properties gear button for the Voltage Sensor Ch. A. Set the Gain to 1000x.
4. If the Current Probe is not visible in the Data Summary under the Voltage Sensor (Ch. A), click on the eye (visibility) icon next to the Voltage Sensor (Ch. A) and select the Current Probe.

Lab experiment #9 [Based on PASCO Kirchoff's Circuit Laws lab, written by Chuck Hunt]

5. Create a graph of Output Voltage vs. Current Probe (Ch. A). Create another graph of Output Voltage vs. Output Current.
6. On the Sampling Control Bar at the bottom of the Capstone page, set the Common Sample Rate to 50 Hz.
7. Construct the circuit shown in Figures 3 through 5. A  $100\ \Omega$  ( $\pm 5\%$ ) (brown-black-brown-gold) resistor is connected in series with a Current Probe (the A with a circle around it [for ammeter] on the circuit diagram). A Voltage sensor is attached to the Current Probe as shown and then to Ch. A on the 850 Universal Interface. It is important to observe polarity by connecting red to red and black to black where possible. There is a second ammeter built into the 850 Output 1.

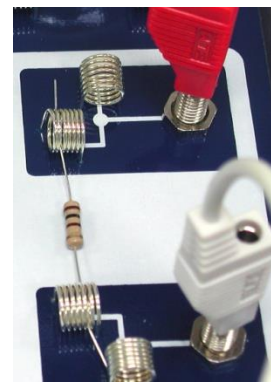
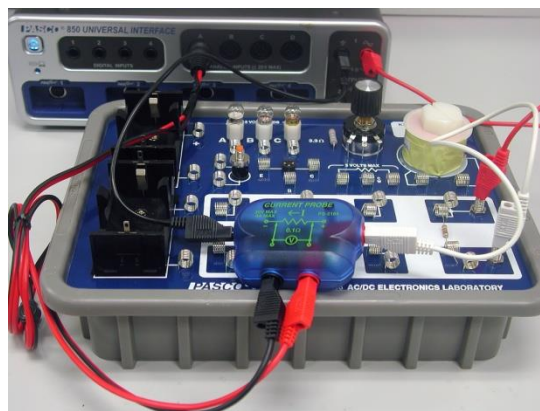
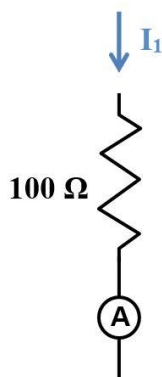

Fig. 3: Calibration Circuit

Figure 4: Ammeter Calibration

Figure 5:  $100\ \Omega$  Resistor

The color codes on the resistors only have a precision of  $\pm 5\%$ . This can be improved to about  $\pm 1\%$  using the calibration circuit.

1. Click open the Signal Generator at the left of the page. Set Waveform to Triangle at 10 Hz and an amplitude of 10 V. Click Auto. Click Signal Generator to close the panel.
2. Click Record. After about 2 seconds, click Stop.
3. For each graph, select a Linear fit.
4. The slope of each line is the measured resistance. Record the slopes and average the two values.
5. Repeat for another  $100\ \Omega$  and a  $330\ \Omega$  (orange-orange-brown-gold) resistor. Make sure you keep track of which  $100\ \Omega$  resistor is  $R_1$  and which is  $R_3$ .

### Ammeter Calibration

The Current Probes work by measuring the voltage drop across a small resistor ( $0.1\ \Omega$  for the Current Probes). Since the sensitivity is about  $0.1\ \text{mA}$ , this means the 850 Universal Interface must measure voltages of  $0.01\ \text{mV}$ . Noise can result in significant zero error. By averaging over

Lab experiment #9 [Based on PASCO Kirchoff's Circuit Laws lab, written by Chuck Hunt]

several seconds we can achieve a precision of 0.1-0.2 mA, but with systematic errors that can approach 1 milliamp. We can correct for this with a brief calibration procedure.

1. Make sure the 100  $\Omega$  resistor is back in the calibration circuit (see Figure 4).
2. Click open the Signal Generator at the left of the screen. Set 850 Output 1 for a DC Waveform and a DC Voltage of 0 V. Click the On button.
3. Create a Digits display with Current Probe (Ch.A). Select units of mA and in the Statistics, turn on the Mean.
4. Click Record.
5. Wait several seconds until the measured mean current stops varying as the average becomes well defined. Click Stop.
6. Create a table as shown below. In the first column, create a User-Entered Data Set called "Theory Current" with units of mA. In the second column, create a User-Entered Data Set called "A Current" with units of mA. In the third column, create a calculation called "A Correct" with units of mA:

$$A \text{ correct} = -[A \text{ Current (mA)}] + [\text{Theory Current (mA)}]$$

Table I: Ammeter Calibration Data

Theory Current (mA)	A Current (mA)	A correct (mA)
0.0		
10.0		
20.0		
30.0		
40.0		
50.0		
60.0		
70.0		

7. Enter the value in the second column of the first row of Table I.
8. Click Delete Last Run at the bottom of the screen.
9. In the Signal Generator panel, increase the voltage by 1 V and repeat. Then repeat, increasing the voltage by 1 V each time until 7 V is reached. Enter the values in the appropriate line. Turn Signal Generator off.
10. The Theory Current in column 1 is calculated assuming that the resistance is exactly 100  $\Omega$ . If your value is different, correct the first column by calculating  $I = V/R$  using your exact R.



Lab experiment #9 [Based on PASCO Kirchoff's Circuit Laws lab, written by Chuck Hunt]

Analog input C is attached to the lower banana input ( $V_C$ ) on the circuit board. The red lead from Analog input B is attached to the white wire coming from the junction point A between the three resistors. It will measure  $V_A$ .

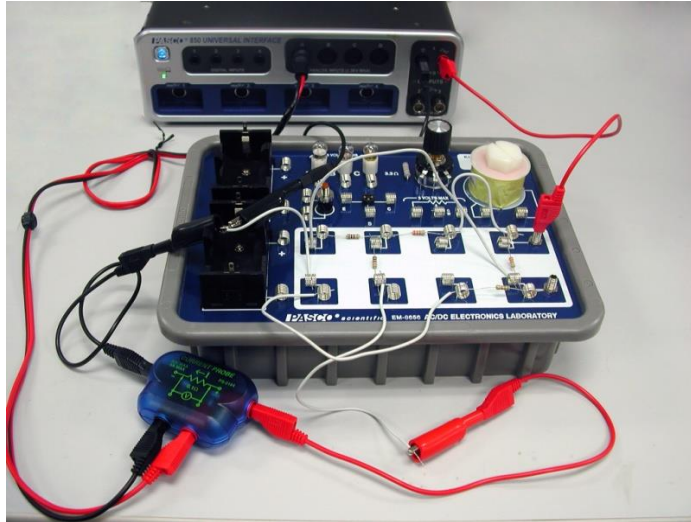

Figure 8: Hooking Up the Ammeter

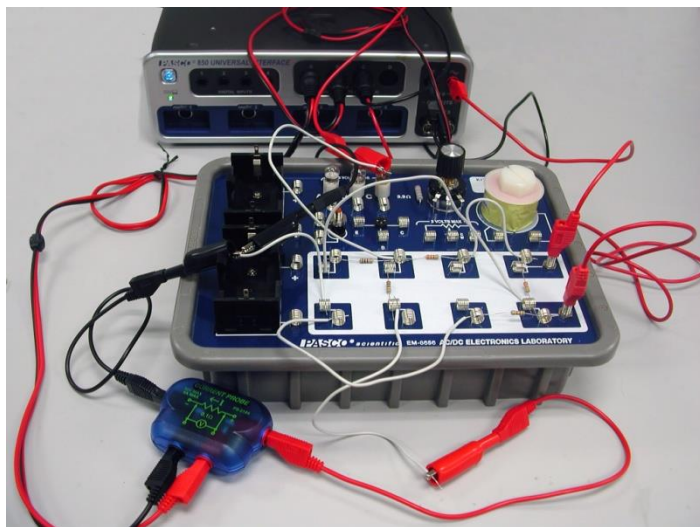

Figure 9: Connecting the Voltage Probes

## DC Current Procedure

1. Click open the Signal Generator at the left of the screen. Set 850 Output 1 for a DC Waveform and a DC Voltage of 15 V. Click the Auto button.
2. Open the Calculator and create two calculations, both with units of A:

$$I_1 \text{ cal} = ([\text{Voltage, Ch C (V)}] - [\text{Voltage, Ch B (V)}]) / [R_1 - 100 (\Omega)]$$

$$I_2 \text{ cal} = ([\text{Output Voltage, Ch O1 (V)}] - [\text{Voltage, Ch B (V)}]) / [R_2 - 330 (\Omega)]$$

Lab experiment #9 [Based on PASCO Kirchoff's Circuit Laws lab, written by Chuck Hunt]

3. Create Digits displays for V(Ch. B), V(Ch. C), Output Voltage, Current Probe (Ch. A),  $I_1$  cal, and  $I_2$  cal. For the Current Probe Digits, choose the Mean on the statistics.
4. Click Record.
5. Wait several seconds until the measured current stops varying as the average from the Current Probe becomes well defined. Click Stop.
6. Record the voltage and current values from all the Digits displays.

*Note: Although the total current,  $I_3$ , is measured directly,  $I_1$  and  $I_2$  are calculated from the measured voltage drops using  $\Delta V/R = I$ . Although it would be nice to measure them directly, shifting the ammeter ground introduces error of a few mA which decreases the precision of the experiment since the current values are quite small. This really is not a limitation on the results since this is what the ammeter does as well. It measures the voltage drop across a  $0.1 \Omega$  precision resistor. We have just made our own ammeters by replacing the  $0.1 \Omega$  resistor with the known values for the resistors in the circuit.*

## DC Analysis

1. Apply the correction from the Current Correction graph to  $i_A$  ave to get a corrected value for  $I_3$  and record it.
2. Using Equations 3-5 from Theory, calculate values for  $I_1$ ,  $I_2$ , and  $I_3$ . These three equations may be solved simultaneously, or you may solve them using a  $3 \times 4$  augmented matrix.
3. Calculate the theory values that you should expect for the three currents and the percent difference from measured and record them.

## Conclusion

How well did your values check out?